

# ANTI-VIBRATION & SPRINGS

N2

## Wire Cable Reel

2.5m Extension

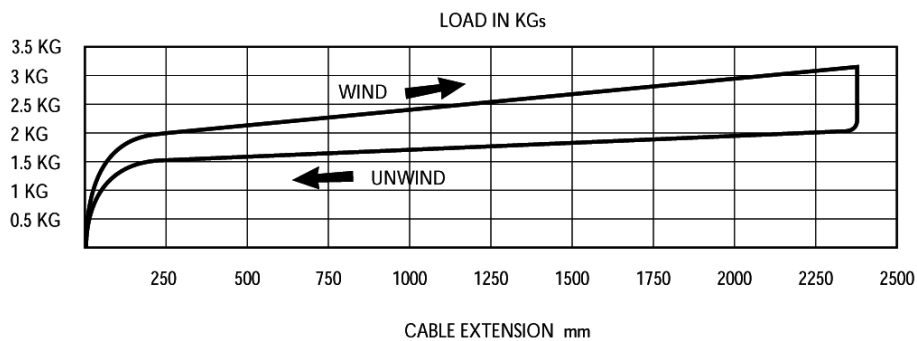
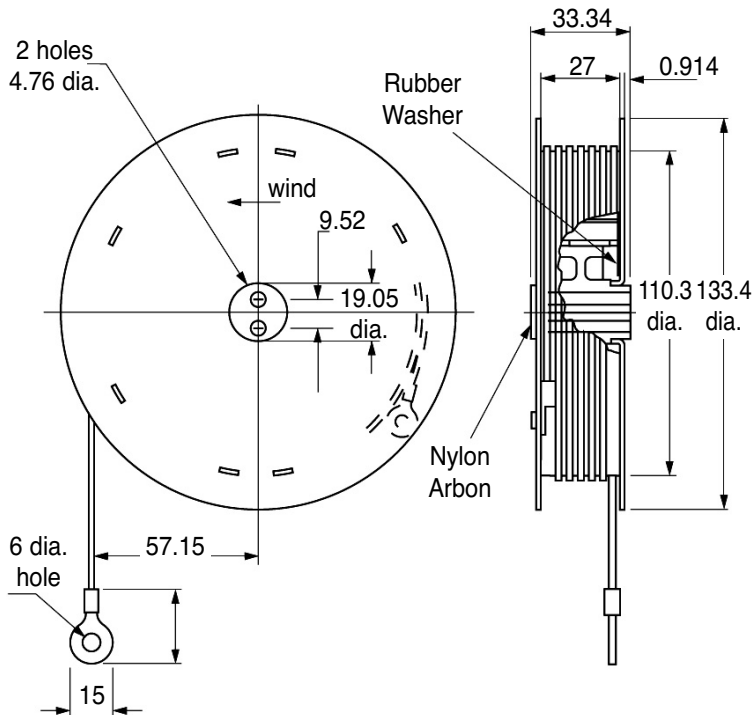

Part Number	Description	Price Each
N2933	2.5m of cable extension	£57.46

### Material

**Cable:** 2540mm of 1.65 diameter 4x7 galvanised steel wire nylon covered 2.62 o/d.

### Features

- It is a 2.2mm galvanised steel wire with nylon covering and low gradient residually stressed power spring. This standard option has many applications, used in the assistance of door opening in tube trains & lifts through to counterbalancing of hospital x-ray equipment.
- If reel rewinds out of control the spring will slip its fixing on the arbor, be undamaged and re-connect on subsequent rewind. Spring is not annealed at end and winds onto a large arbor (44.45 diameter).