

SL

ANTI-VIBRATION & SPRINGS

Motor Spring Assemblies

Cased

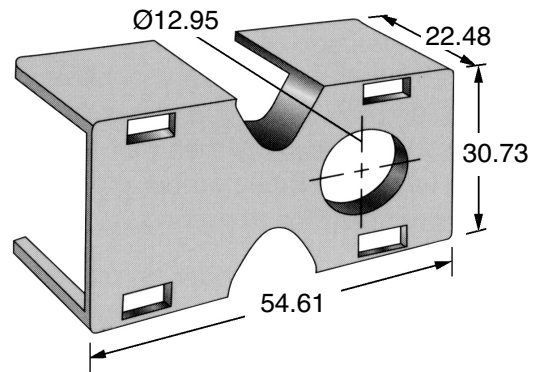
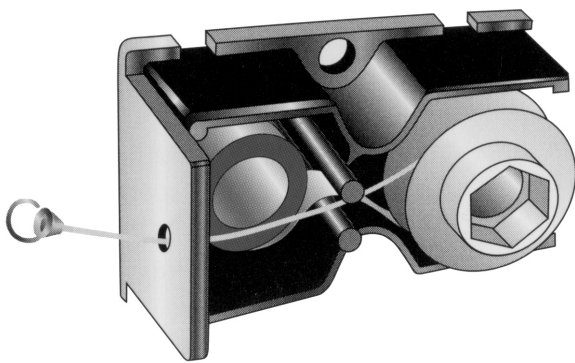
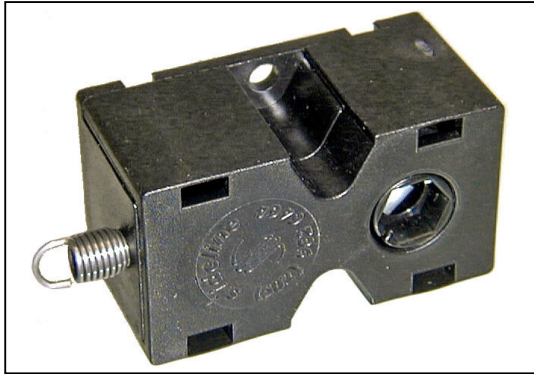

End Fitting

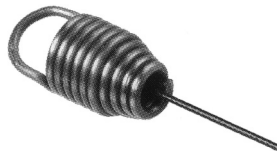

Spring Hook

Part Number	Approx. Counter-Balances* Kg	Number of revolutions	Average Fatigue Life Cycles	Travel mm	Price Each
SL374-S	0.136	25	30000	915	£11.90

Material

Spring: Stainless Steel 301 S21 Grade
Bobbin: Zytel 101L
Housing: Black Delrin 500P
Cord: Steel Cable, Plastic Coated

Performance

Average Fatigue Life: 30,000 cycles.

Other Info.

Constant force motor springs offer a compact alternative for long running motors. 50 turns or more at near constant torque can be achieved. Typically used for retrieving and returning, the motor spring has many uses.

+44 (0)1246 455500
 +44 (0)1246 455522

ondrives

sales@ondrives.com
 www.ondrives.com

Product information updated 1st April 2010 and subject to change. Please contact Sales for the latest prices and availability.