

RS

LINEAR MOTION

Linear Drive Nuts

Backlash Free

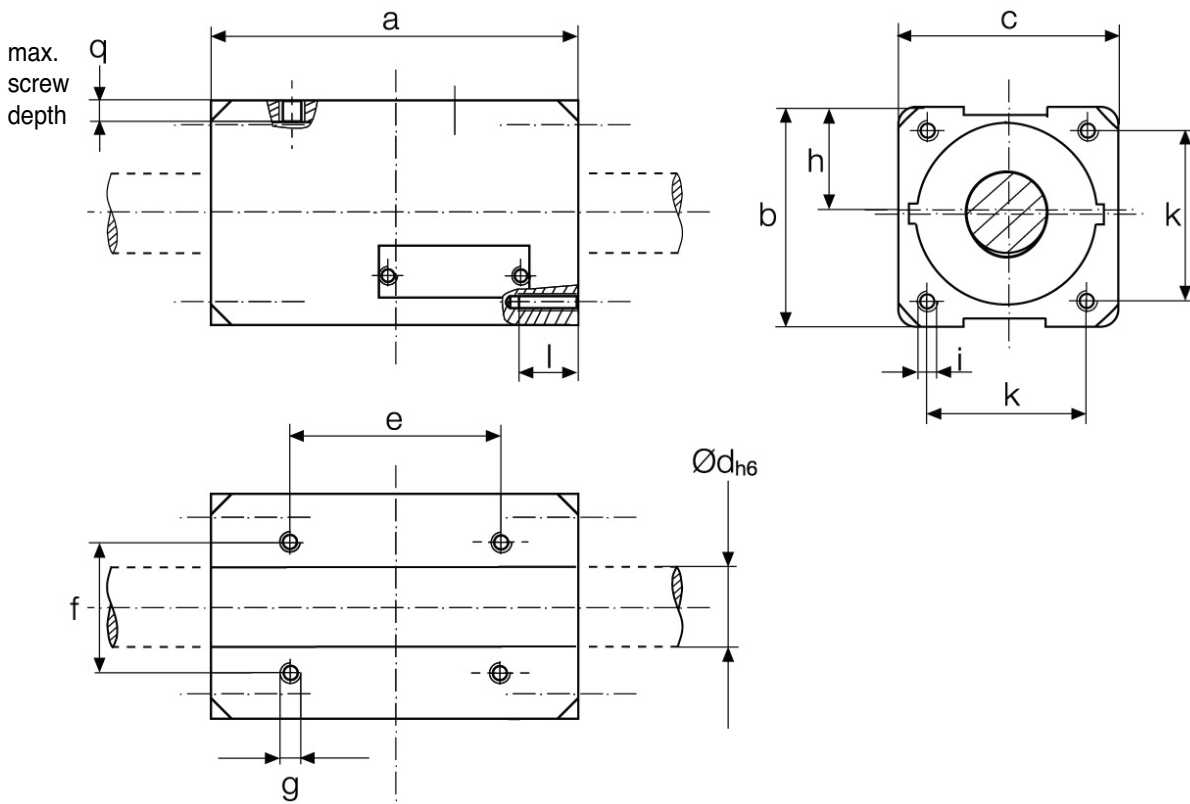

Part Number	Shafts (to suit)	Weight m Kg	a*	a1*	b	c	dh6	e	f	g	h ^{+0.3}	i	k	l	q
RS3-10-4	Z-10-1000A	0.14	47	65	35	35	10	30	18	M4	17.3	M3	26	6	5
RS4-10-4	Z-10-1000A	0.18	55	73	35	35	10	30	18	M4	17.3	M3	26	6	5
RS4-15-4	Z-15-1000A	0.23	62	82	40	40	15	26	18	M4	19.6	M4	30	8	5
RS4-20-4	Z-20-1000A	0.55	83	108	52	52	20	40	30	M5	26.0	M5	40	11	8
RS4-25-4	Z-25-1000A	0.70	85	110	60	60	25	40	30	M5	29.4	M5	45	10	9
RS4-35-4	Z-35-1000A	1.55	105	126	80	80	35	50	40	M6	40.0	M6	60	12	13
RS4-50-3	Z-50-1000A	2.70	120	140	100	100	50	50	50	M8	48.8	-	-	-	16
RS4-60-3	Z-60-1000A	4.20	130	156	120	120	60	69	62	M10	58.4	-	-	-	15

Note: Shafts are CK53 and 1000mm long as standard. *If wipers are used, dimension a becomes a1.

Material

Housing: Aluminium
Bearings: Tool/bearing Steel
Inserts: Plastic

+44 (0)1246 455500
+44 (0)1246 455522

ondrives

sales@ondrives.com
www.ondrives.com

Product information updated 1st April 2011 and subject to change. Please contact Sales for the latest prices and availability.

LINEAR MOTION

RS

Linear Drive Nuts

Backlash Free

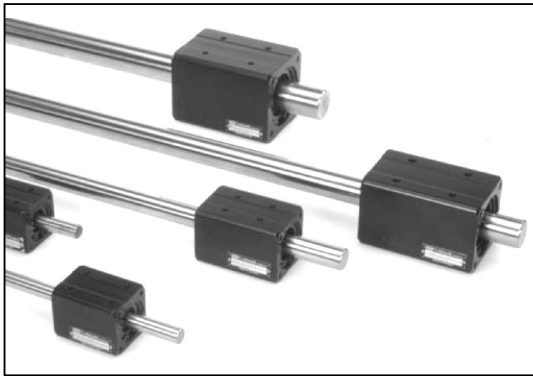

Rino linear drive nuts are non-positive drives which convert the rotation of a plain round shaft into linear motion. The effect is achieved by pressing specially crowned rolling rings against the shaft and allowing them to roll on the surface of the shaft at an angle which determines their pitch.

Extra components available to buy - POA

F - Free Movement Lever, mechanical

When operated, the nut can slide freely along the shaft.

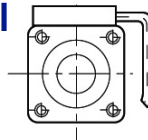

Adapter

For twist free coupling systems.

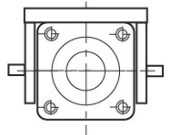

Wipers

For sealing between nut and shaft (to +70°C). Attention! For units with wipers please note dimension a1.



R - Steady Rollers

Rolls on Linear Drive Nut (in conjunction with a guide bar) prevent the rotation of the nut on the shaft.

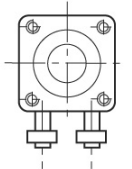

Discounts: 5+ -10%

Max. Available Side Thrust FRS (N)	Technical Details Idling Torque M0 (Ncm)	Max. Pitch h (mm)	Price Each Drive Nuts	Price Each 1 - 5 Shafts
100	1.8	5.0	£P.O.A	£29.76
200	3.0	5.0	£P.O.A	£29.76
260	5.0	7.5	£P.O.A	£51.36
420	10.0	10.0	£P.O.A	£38.28
600	20.0	12.5	£P.O.A	£55.31
900	45.0	17.5	£P.O.A	£P.O.A
1300	140.0	25.0	£P.O.A	£172.72
2000	200.0	30.0	£P.O.A	£245.89

Features

- Backlash-free
- Overload protection
- Low maintenance
- Linked nuts for higher side thrust
- Resistant to vibrations
- High efficiency
- Free-movement lever
- Left and right-hand pitch on the same shaft
- Compact design
- Quiet in operation
- Good sealing possibilities
- Typical applications; linear motion drives, materials handling systems, control systems, measurement and inspection technology

+44 (0)1246 455500
+44 (0)1246 455522

ondrives

sales@ondrives.com
www.ondrives.com

Product information updated 1st April 2011 and subject to change. Please contact Sales for the latest prices and availability.

LINEAR MOTION

Linear Drive Nuts

Selection

Formulae and Related Units

d(mm)	= shaft diameter
F(N)	= side thrust required
FRS(N)	= side thrust produced by Linear Drive Nut type RS
FR(N)	= force of friction (FN•μ) only relevant when the associated mass is mounted on its own independent carriage
FN(N)	= normal force of total weight of associated mass and carriage
μ	= coefficient of friction
FZ(N)	= additional force eg: component of the cutting force of a separator
f(mm)	= shaft sag from diagram
g(m/s ²)	= acceleration due to gravity (9.81 m/s ²). Note: for horizontal applications m•g=0

h(mm)	= Drive nut pitch (travel per shaft revolution)
l(mm)	= length of shaft between centre of bearing brackets
m(kg)	= total mass to be moved, including Drive Nut, connections, etc.
Md(Ncm)	= drive torque
Mo(Ncm)	= idling torque
n(r.p.m.)	= shaft speed
ncrit(r.p.m.)	= critical shaft speed
P(kW)	= drive power required
t(s)	= acceleration or braking time
v(m/sec)	= maximum speed of travel
C(N)	= dynamic loading of Rolling Rings
PR(N)	= radial loading of Rolling Rings

1. Side thrust

$$F = 2 \left(\frac{m \cdot v}{t} + m \cdot g \right) + FR + FZ$$

A drive nut should be selected which has a greater side thrust than the value calculated.

$$F < FRS$$

Several similar Drive Nuts can be coupled together if available space so dictates. The total thrust available is the sum of the individual values.

2. Shaft speed

$$n = \frac{v \cdot 6 \cdot 10^4}{h_{max}}$$

2.1 Max. shaft speed

RS 3-10-4	=	10000	r.p.m.
RS 4-15-4	=	8000	r.p.m.
RS 4-20-4	=	7000	r.p.m.
RS 4-25-4	=	6000	r.p.m.
RS 4-35-4	=	4000	r.p.m.
RS 4-50-3	=	3400	r.p.m.
RS 4-60-3	=	2500	r.p.m.

2.2 Critical shaft speed

$$n_{crit} = 1.225 \cdot 10^8 \frac{d}{l^2}$$

Note: Depending upon its quality, the shaft can go out of balance at a speed of up to 25% lower than that specified above.

If it is necessary to go through a critical range in order to reach the operational speed, this can lead to short term shaft vibration. This has no effect on the operation of the Drive Nut. If the operational speed is in the critical speed range, this can be rectified as follows:

1. With a double bearing support at one end, increase factor approx 1.5
2. With double bearing supports at both ends, increase factor approx 2.2

The distance between the bearing support brackets should be at least 2.5 x the diameter of the shaft.

3. Drive torque

$$M_d = \frac{FRS \cdot h}{20 \cdot \pi} + M_o$$

Values for MO to be taken from the technical detail tables.

4. Shaft sag (Diagram)

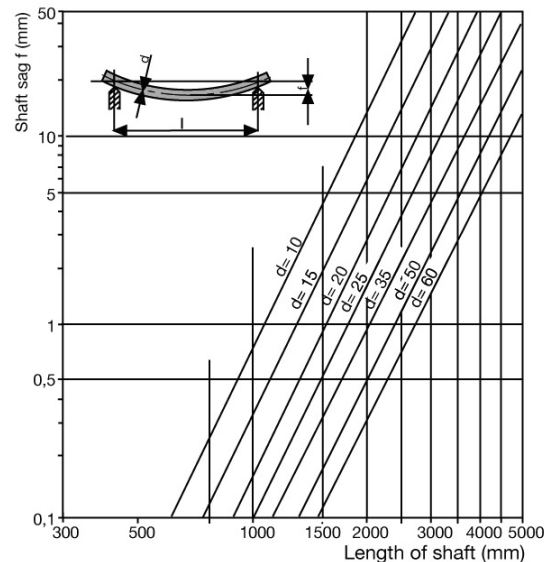

T
E
C
H
N
I
C
A
L

LINEAR MOTION

Linear Drive Nuts

Selection

5. Calc. of the operational life of Rolling Rings

a. Select C

Type	C(N)
RS 10	4620
RS 15	5590
RS 20	9360
RS 25	11200
RS 35	15900
RS 50	21600
RS 60	29600

b. Calculate PR

$$\begin{aligned} \text{RS 10} & : PR = 5 \cdot FRS^* \\ \text{RS 15 - 60} & : PR = 2.5 \cdot FRS^* \end{aligned}$$

*F = Calculated value of the side thrust according to 1. Only if increasing of operational life time of the rolling rings is really necessary. In case of order it is an absolute must to mention.

c. Divide C by PR

d. Calculate the required shaft speed

$$n = \frac{v \cdot 6 \cdot 10^4}{h_{max}}$$

5. Determine the operation life in hours from the nomogram

Diagram shown on right.

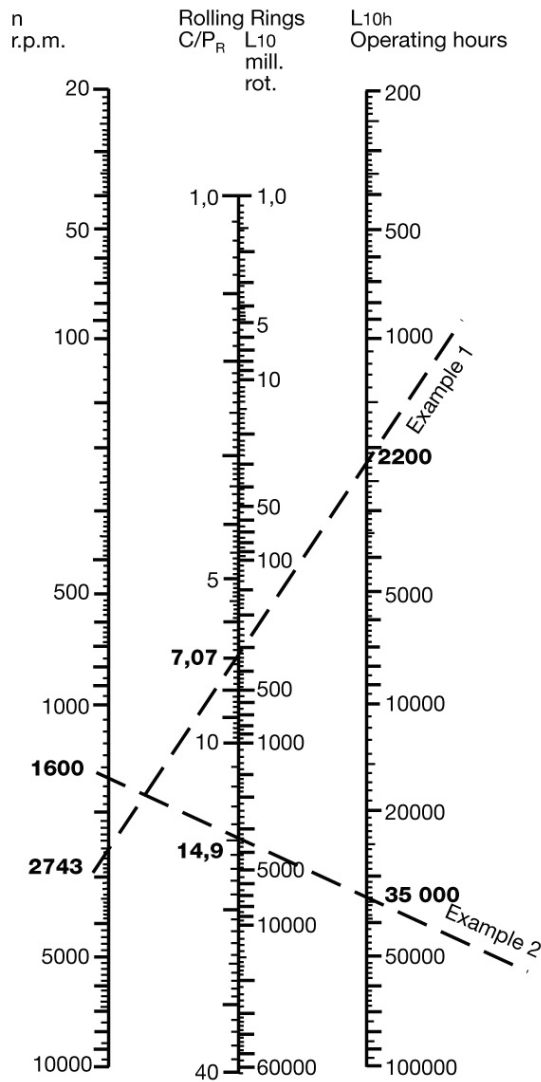

Example 1	Example 2
RS4-35-4R17.5 speed 0.8 m/s	RS4-35-4R7.5 Reduced side thrust 150 N speed 0.2 m/s
1. C = 15900	1. C = 5590
2. PR = 2.5 • 900 N = 2250 N	2. PR = 2.5 • 150 N = 375 N
3. $\frac{C}{PR} = \frac{15900}{2250} = 7.07$	3. $\frac{C}{PR} = \frac{5590}{375} = 14.9$
4. $n = \frac{0.8 \cdot 6 \cdot 10^4}{17.5} = 2743$ rpm	4. $n = \frac{0.2 \cdot 6 \cdot 10^4}{7.5} = 1600$ rpm
5. L10h = 2200 operating hours	5. L10h = 35000 operating hours

LINEAR MOTION CALCULATING THE

LINEAR MOTION

Linear Drive Nuts Operational Guide

T
E
C
H
N
I
C
A
L

1. Shaft material

1.1 Basic requirements

Rino Linear Drives should only be used in conjunction with steel shafts manufactured from induction surface hardened, ground and finished bar of the following quality, minimum:

- surface hardness: 50 HRC
- tolerance on diameter: h6
- out of roundness: maximum one half of the diameter variation permitted by ISO tolerance h6
- true running tolerance (DIN ISO 1101): ≤ 0.1 mm/m

1.2 Precision shaft

Standard: Material similar to Cf53, Mat. –Nr. 1.1213, induction surface hardened, 60-64 HRC
Rust resistant: Material X40 Cr 13, Mat – Nr. 1.4034, induction surface hardened, 51-55 HRC
Rust & acid resistant: Material X 90 CrMoV 18, Mat – Nr. 1.4112, induction surface hardened, 52-56 HRC

- all ground and super finished
- surface roughness: mean value (DIN 4768 T.1) $Ra: \leq 0.35 \mu\text{m}$
- tolerance on diameter: h6
- out of roundness: maximum one half of the diameter variation permitted by ISO tolerance h6
- true running tolerance (DIN ISO 1101): ≤ 0.1 mm/m

1.3 Precision shafts with enhanced true running tolerance

Available in the above styles, but

- true running tolerance (DIN ISO 1101): 0.03mm/m

1.4 Leading end chamfer

The leading end of the shaft should be chamfered to avoid damage to the Rolling Rings when screwing the unit onto the shaft.

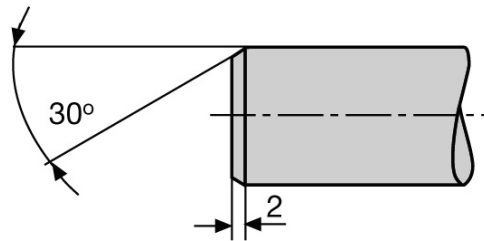

2. Pitch

The standard pitch is $0.5 \times d$. This can be ordered as either a right or left-handed pitch. Unless otherwise specified, units having a right-handed pitch will be supplied. Subsequent alterations to the pitch are possible with units having a design category –4 reference by changing the associated pitch control wedges.

Non-standard pitches 0.1 – 0.2 – 0.3 and $0.4 \times d$ are available. In this version reduction of the side thrust is recommended to improve the smooth running.

LINEAR MOTION

Linear Drive Nuts

Operational Guide

3. Separately carried loads

If Rino Linear Drive Nuts are used to move separately carried loads, allowance should be made in the coupling to compensate for any misalignment between the drive shaft and the carriage. The available side thrust will otherwise be affected. If the application so permits, we recommend the use of our twist-free coupling system.

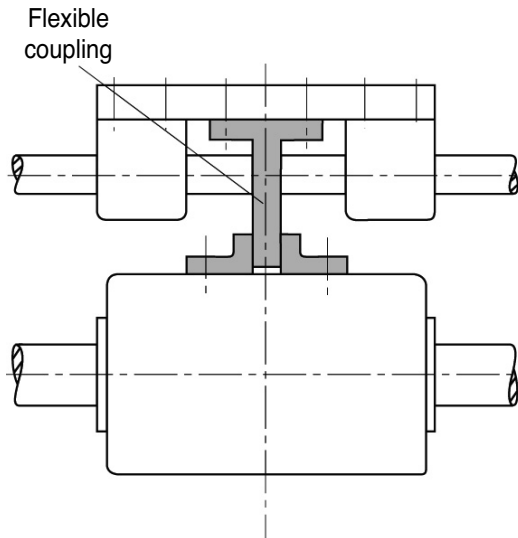

Twist-free coupling system

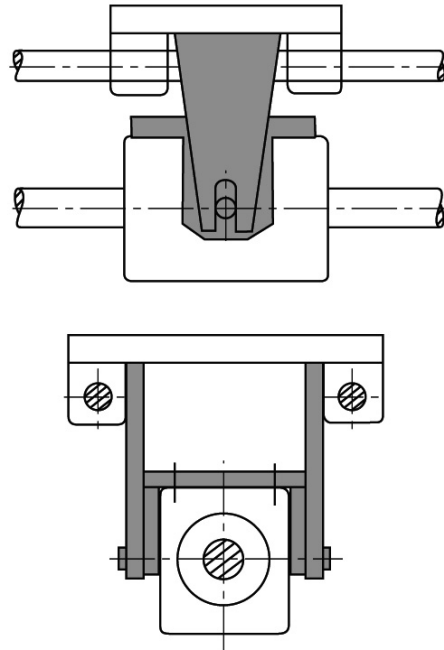

4. Vertical applications

For vertical applications we advise the use of a directly braked motor so as to avoid the possibility of the shaft rotating backwards and the Drive Nut falling due to the high efficiency of the drive.

Depending upon the application (safety considerations and value of the installation) a reserve of side thrust should be built in (using a second Drive Nut).

With units having a free-movement lever, care must be taken before its operation to ensure that they are unable to drop in an uncontrolled manner – danger of injury!

5. Temperature range

Linear Drive Nuts are suitable for operation at temperatures from -10°C to $+70^{\circ}\text{C}$. Please enquire for other temperatures.

6. Maintenance

For the lubrication of the shaft, commercially available MoS₂-free ball bearing greases can be used, eg: SKF Alfalub LGM2, Shell Alvania R2 or G2, Esso Beacon 2, BP Energrease LS2.

Procedure: Clean the shaft and spread the grease as thinly as possible with a rag.

Frequency: Once every ten weeks.

7. Symmetry

The maximum difference in pitch for the two directions of travel is 2%.

We therefore recommend the use of positional sensors for positioning applications.