

# LINEAR MOTION

**RPB-XX**  
**BSB-XX**

## Ballscrew Bearing Units

Machining Recommendations Available for EBB, BNT & BLK Type



### RPBXX-SCREW LH or RH Type (Rigid Support)

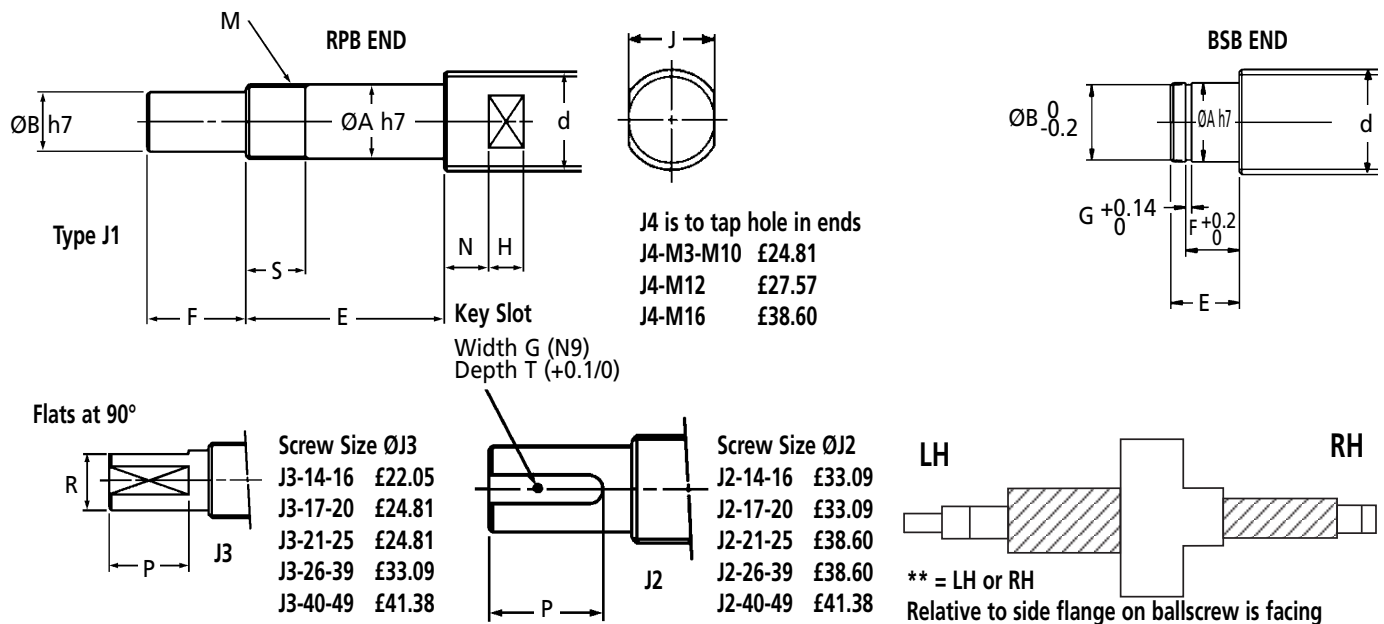

Machining Part Number	d	A	B	E	F 1)	Type J M	S	J	N	H	G	Keyway Type J2 T	P	Flats Type J2 R	P	Price Each
RPB10-SW-XX	14-15	10	8	39	15	M10x1.0	16	10	5	7	2	1.2	11	7.5	11	£145.47
RPB12-SW-XX	16-18	12	10	39	15	M12x1.0	14	13	6	8	3	1.8	12	9.5	12	£145.47
RPB15-SW-XX	20	15	12	40	20	M15x1.0	12	16	6	9	4	2.5	16	11.3	16	£193.39
RPB17-SW-XX	25	17	15	53	23	M17x1.0	17	18	7	10	5	3.0	21	14.3	21	£193.39
RPB20-SW-XX	28-32	20	17	53	25	M20x1.0	15	21-27	8-9	11-13	5	3.0	21	16.0	21	£193.39
RPB25-SW-XX	36	25	20	65	30	M25x1.5	18	27	10	13	6	3.5	25	19.0	25	£287.51
RPB30-SW-XX	40	30	25	72	38	M30x1.5	25	32	10	15	8	4.0	32	23.5	32	£287.51
RPB40-SW-XX	50-55	40	35	98	50	M40x1.5	35	41-46	14	19-20	10	5.0	45	33.0	45	£287.51

1) Drive end length F may be customer specified to suit drive coupling. If not specified the length in the table will be used.

Machining Part No.	A	E	Type K B	F	G	Price Each
BSB10-SW-XX	8	10	7.6	7.90	0.90	£71.86
BSB12-SW-XX	10	11	9.6	9.15	1.15	£71.86
BSB15-SW-XX	15	13	14.3	10.15	1.15	£95.82
BSB17-SW-XX	17	16	16.2	13.15	1.15	£95.82
BSB20-SW-XX	20	16	19.0	13.35	1.35	£95.82
BSB25-SW-XX	25	20	23.9	16.35	1.35	£143.74
BSB30-SW-XX	30	21	28.6	17.75	1.75	£143.74
BSB40-SW-XX	40	23	38.0	19.95	1.95	£143.74

+44 (0)1246 455500  
+44 (0)1246 455522

**ondrives**

sales@ondrives.com  
www.ondrives.com

Product information updated 1st April 2011 and subject to change. Please contact Sales for the latest prices and availability.