

COMMERCIAL GEARS

SMS

Machined Spiral Bevel Gears α 20° PA

1:1 Ratio

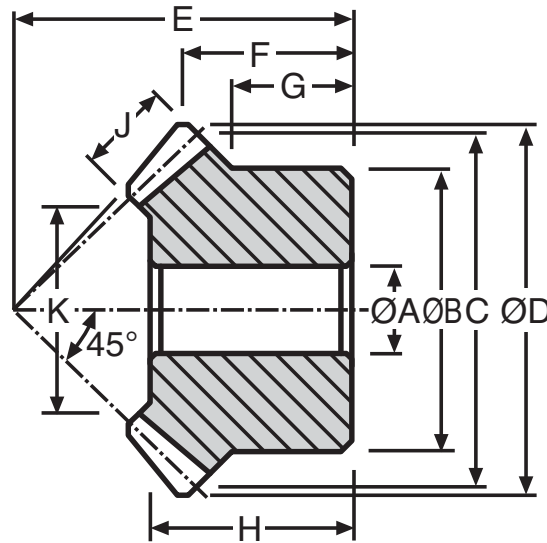
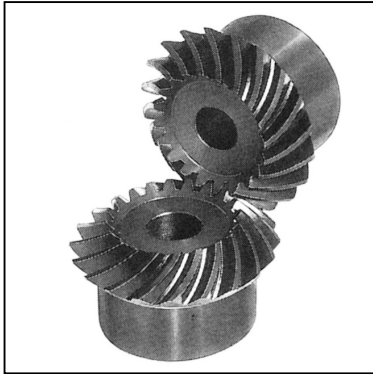

Discounts: 6+ -12% 20+ -25%

Part Number RH	Part Number LH	Teeth Z	Mod	ØA	B	C	D	E	F	G	H	J	K	Weight (kg)	Price Each 1 - 5
SMS1-20R	SMS1-20L	20	1.0	6	16	20.0	21.2	20	10.6	8.0	12	5	12	0.020	£27.56
SMS1-25R	SMS1-25L	25	1.0	8	20	25.0	26.2	23	11.1	8.0	14	6	16	0.050	£38.96
SMS1-30R	SMS1-30L	30	1.0	8	24	30.0	31.2	28	13.6	10.0	16	6	20	0.050	£52.23
SMS1.25-20R	SMS1.25-20L	20	1.25	8	22	25.0	26.5	23	11.3	9.0	13	6	15	0.040	£40.42
SMS1.25-25R	SMS1.25-25L	25	1.25	8	25	31.2	32.8	28	13.1	9.3	18	7	20	0.060	£51.13
SMS1.25-30R	SMS1.25-30L	30	1.25	10	30	37.5	39.0	36	18.0	13.5	21	8	25	0.130	£64.00
SMS1.5-20R	SMS1.5-20L	20	1.5	8	26	30.0	31.8	30	15.9	13.0	19	8	17	0.070	£43.64
SMS1.5-25R	SMS1.5-25L	25	1.5	10	30	37.5	39.3	34	16.2	11.5	19	9	23	0.120	£58.84
SMS1.5-30R	SMS1.5-30L	30	1.5	10	35	45.0	46.8	43	21.4	16.0	25	10	29	0.200	£73.58
SMS2-20R	SMS2-20L	25	2.0	12	40	50.0	52.4	40	16.2	10.0	20	12	31	0.20	£49.63
SMS2-25R	SMS2-25L	30	2.0	12	45	60.0	62.4	50	21.2	12.5	25	12	41	0.37	£122.62
SMS2-30R	SMS2-30L	20	2.5	14	42	50.0	52.9	48	24.5	19.0	29	12	31	0.30	£156.68
SMS2.5-20R	SMS2.5-20L	25	2.5	16	50	62.5	65.5	50	20.3	12.5	26	15	59	0.40	£115.81
SMS2.5-25R	SMS2.5-25L	30	2.5	16	60	75.0	78.0	62	26.0	17.0	32	15	51	0.77	£149.88
SMS2.5-30R	SMS2.5-30L	30	2.5	16	60	75.0	78.0	62	26.0	17.0	32	15	51	0.77	£188.03
SMS3-20R	SMS3-20L	20	3.0	16	50	60.0	63.7	58	29.9	23.0	35	15	36	0.50	£156.68
SMS3-25R	SMS3-25L	25	3.0	20	60	75.0	78.8	60	24.4	15.0	32	20	44	0.70	£183.93
SMS3-30R	SMS3-30L	30	3.0	20	70	90.0	93.6	75	31.8	20.0	40	20	59	1.30	£245.26

Material

Steel S45C. Induction hardened teeth. Non-modifiable gears.

35° Spiral angle, 45° Pitch angle.

Face Angle: 20 teeth = 49°12', 25 teeth = 48°22', 30 teeth = 47°48'

Right hand gear, left hand pinion - must be purchased as pairs

+44 (0)1246 455500

+44 (0)1246 455522

ondrives

sales@ondrives.com

www.ondrives.com

Product information updated 1st April 2011 and subject to change. Please contact Sales for the latest prices and availability.