

PP35

e-cad
Drawings
Available

GEARBOXES

Double Reduction Worm Gear Reducers

2.2Nm – 4.1Nm **25:1 - 900:1**

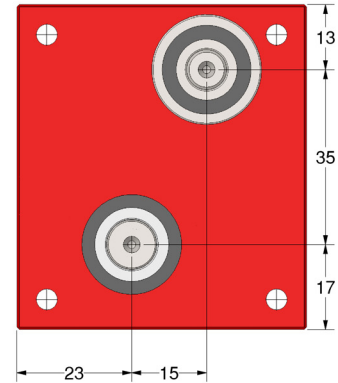
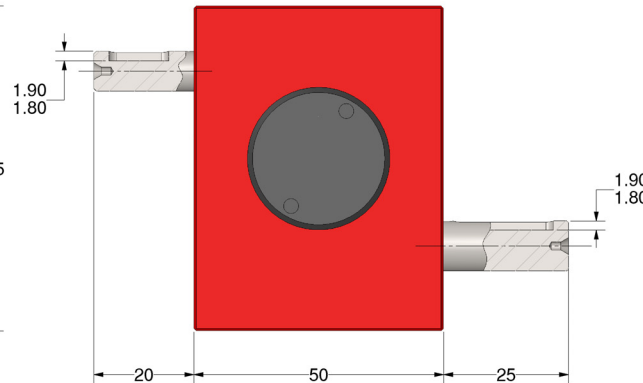
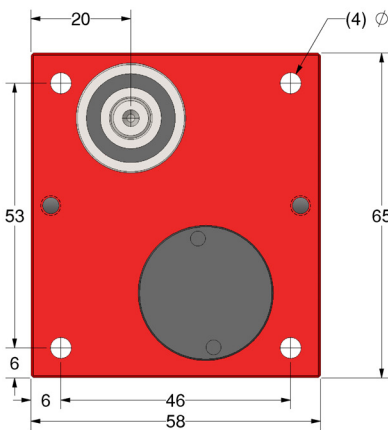
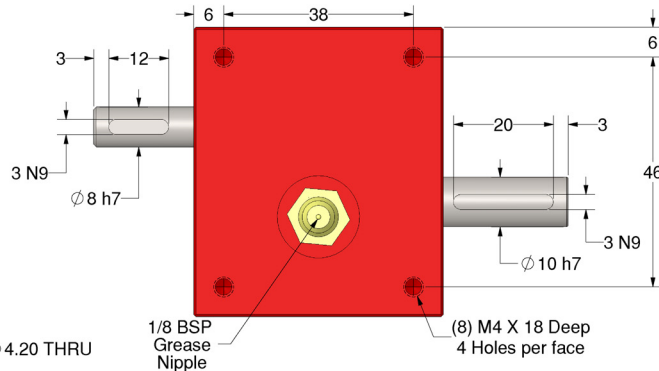

Discounts: 6+ -5% 20+ -10% 50+ -15% 100+ -20%

Part Number	Ratio	Max. Input Rpm	Max. Output Rpm	Efficiency at 1000 Rpm	Self Locking Output	Price Each 1 - 5
PP35-100	100:1	3000	30.00	52%	✗	£251.84
PP35-200	200:1	3000	15.00	45%	✗	£251.84
PP35-400	400:1	3000	7.50	34%	✓	£251.84
PP35-SP	25:1 - 900:1	Special Ratios : Replace SP with required ratio				£294.71

Weight: 0.70kg. **Backlash:** ≈2°. **Greased for life:** Shell Gadus S5 V42P 2.5.

Max Input Speed: 3000 Rpm (short term).

Self Locking Output: Subject to ratio and only applies in static condition.

Amount of locking effect may vary due to manufacturing processes.

Maximum Overhung and Thrust Loads at 1000rpm: Input Overhung Load (F_{ib}) = 6kg.

Output Overhung Load (F_{oa}) = 12kg. Output Thrust Load (F_a) = 10kg.

Output Keys: KK3-12 £0.88, KK3-20 £0.91.

Standard Shaft Rotation Direction is Opposite. Same direction available at SP Price.

Testing in your application is necessary.

You will need to assess duty cycles and confirm suitability with your own calculations.

All figures listed are to be used for guidance only.

Output Torque Nm

Rpm Input	Reduction Ratio		
	100:1	200:1	400:1
3000	2.2	2.3	2.5
2000	2.5	2.7	2.8
1000	2.8	3.0	3.1
500	3.1	3.5	3.6
100	3.8	3.9	4.0
50	3.9	4.0	4.0
10	4.0	4.1	4.1

+44 (0)1246 455500
+44 (0)1246 455522

ondrives

sales@ondrives.com
www.ondrives.com

Product information updated 1st April 2011 and subject to change. Please contact Sales for the latest prices and availability.

GEARBOXES

Double Reduction Worm Gear Reducers

6.5Nm – 12.8Nm **25:1 - 900:1**

e-cad
Drawings
Available

PP50

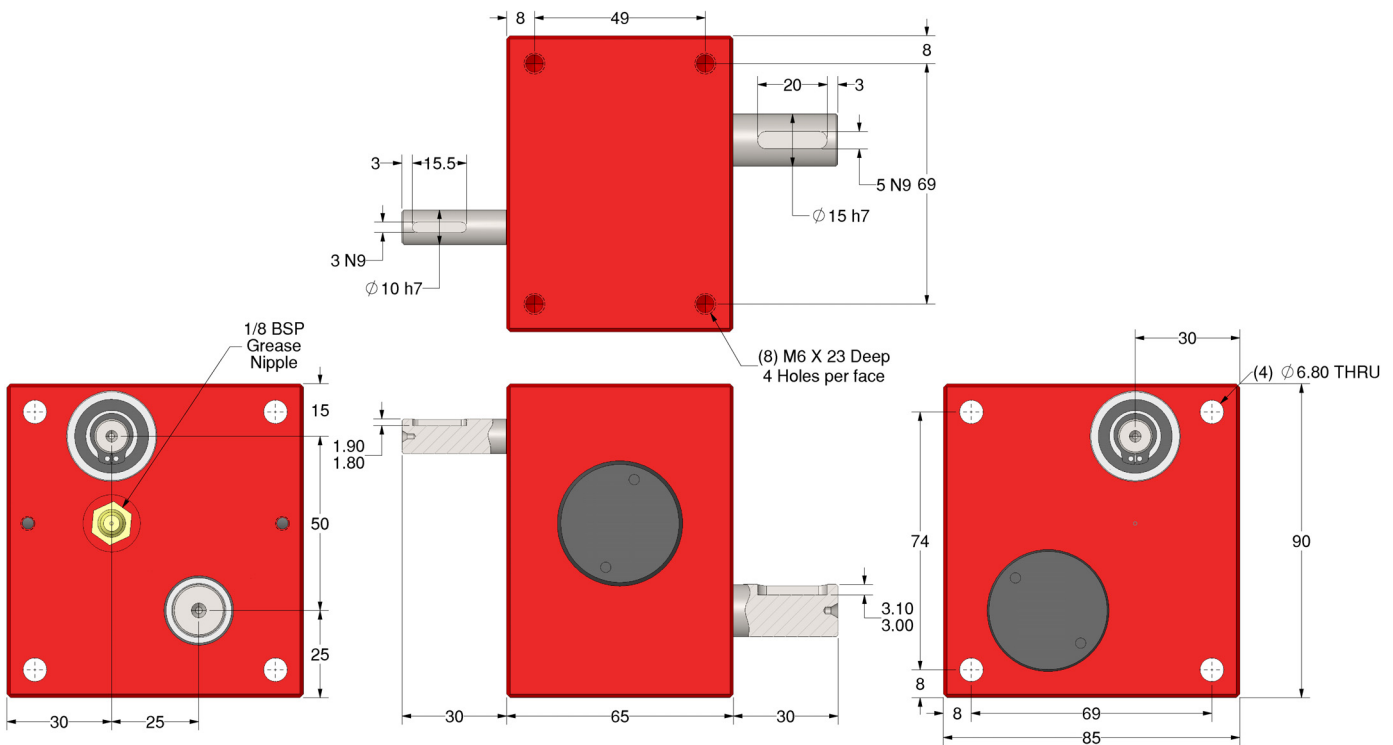

Discounts: 6+ -5% 20+ -10% 50+ -15% 100+ -20%

Part Number	Ratio	Max. Input Rpm	Max. Output Rpm	Efficiency at 1000 Rpm	Self Locking Output	Price Each 1 - 5
PP50-100	100:1	3000	30.00	54%	✗	£294.71
PP50-200	200:1	3000	15.00	48%	✗	£294.71
PP50-400	400:1	3000	7.50	36%	✓	£294.71
PP50-SP	25:1 - 900:1	Special Ratios : Replace SP with required ratio				£334.90

Weight: 1.80kg. **Backlash:** ≈2°. **Greased for life:** Shell Gadus S5 V42P 2.5.

Max Input Speed: 3000 Rpm (short term).

Self Locking Output: Subject to ratio and only applies in static condition.

Amount of locking effect may vary due to manufacturing processes.

Maximum Overhung and Thrust Loads at 1000rpm: Input Overhung Load (F_{xb}) = 10kg.

Output Overhung Load (F_{xa}) = 30kg. Output Thrust Load (F_a) = 20kg.

Output Keys: KK3-15 £0.88, KK5-20 £0.69.

Standard Shaft Rotation Direction is Opposite. Same direction available at SP Price.

Testing in your application is necessary.

You will need to assess duty cycles and confirm suitability with your own calculations.

All figures listed are to be used for guidance only.

Output Torque Nm

Rpm Input	Reduction Ratio		
	100:1	200:1	400:1
3000	6.5	7.1	8.2
2000	7.2	7.8	8.9
1000	6.2	9.0	9.8
500	8.2	10.2	11.5
100	11.0	11.6	12.2
50	12.0	12.3	12.6
10	12.7	12.8	12.8

+44 (0)1246 455500

+44 (0)1246 455522

ondrives

sales@ondrives.com

www.ondrives.com

Product information updated 1st April 2011 and subject to change. Please contact Sales for the latest prices and availability.

PP60

e-cad
Drawings
Available

GEARBOXES

Double Reduction Worm Gear Reducers

17.8Nm – 34Nm **25:1 - 900:1**

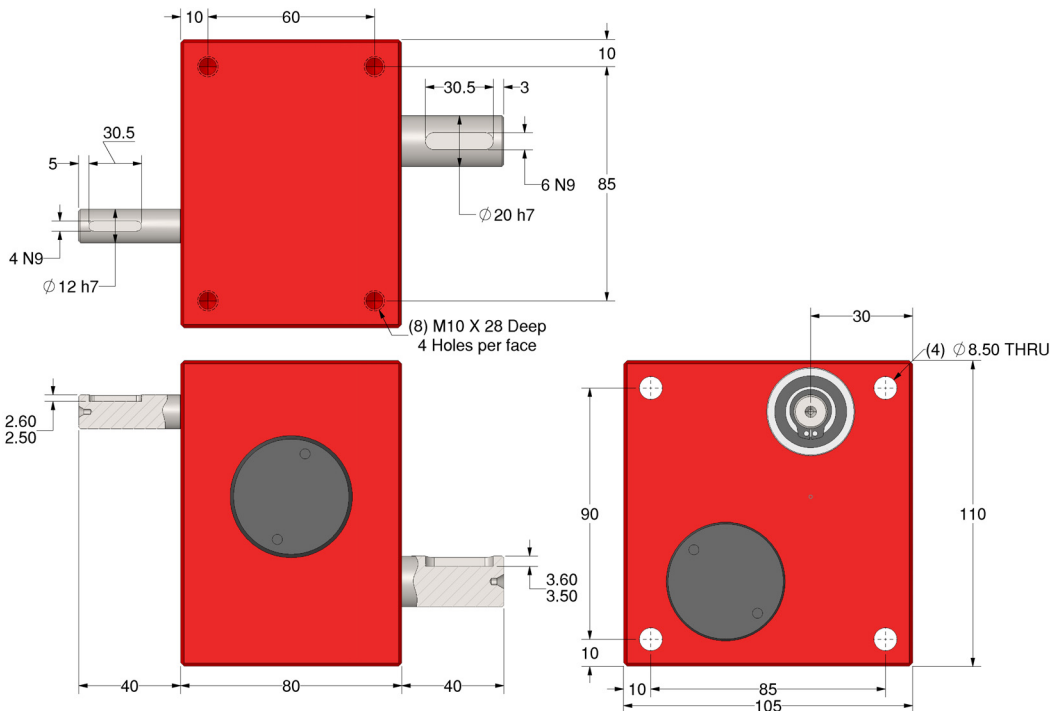
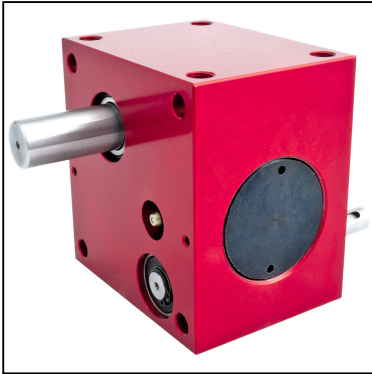

Discounts: 6+ -5% 20+ -10% 50+ -15% 100+ -20%

Part Number	Ratio	Max. Input Rpm	Max. Output Rpm	Efficiency at 1000 Rpm	Self Locking Output	Price Each 1 - 5
PP60-100	100:1	3000	30.00	55%	✗	£372.42
PP60-200	200:1	3000	15.00	50%	✗	£372.42
PP60-400	400:1	3000	7.50	37%	✓	£372.42
PP60-SP	25:1 - 900:1	Special Ratios : Replace SP with required ratio				£462.17

Weight: 3.30kg. **Backlash:** $\approx 2^\circ$. **Greased for life:** Shell Gadus S5 V42P 2.5.

Max Input Speed: 3000 Rpm (short term).

Self Locking Output: Subject to ratio and only applies in static condition.

Amount of locking effect may vary due to manufacturing processes.

Maximum Overhung and Thrust Loads at 1000rpm: Input Overhung Load (F_{ib}) = 15kg.

Output Overhung Load (F_{oa}) = 45kg. Output Thrust Load (F_a) = 35kg.

Output Keys: KK4-30 £0.79, KK6-30 £0.95.

Standard Shaft Rotation Direction is Opposite. Same direction available at SP Price.

Testing in your application is necessary.

You will need to assess duty cycles and confirm suitability with your own calculations.

All figures listed are to be used for guidance only.

Output Torque Nm

Rpm Input	Reduction Ratio		
	100:1	200:1	400:1
3000	17.8	19.4	22.5
2000	20.0	21.6	24.8
1000	22.5	25.0	26.8
500	26.1	28.0	31.6
100	30.5	32.0	34.0
50	33.0	34.0	34.0
10	34.0	34.0	34.0

+44 (0)1246 455500

+44 (0)1246 455522

ondrives

sales@ondrives.com

www.ondrives.com

Product information updated 1st April 2011 and subject to change. Please contact Sales for the latest prices and availability.