

# GEARBOXES

## Precision Worm Gear Reducers

Flange Input 38Nm – 164Nm **5:1 - 120:1**

e-cad  
Drawings  
Available

**PF70**

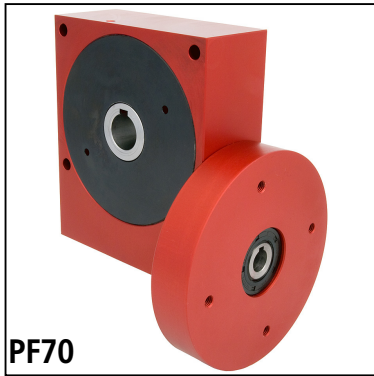

**PF70**

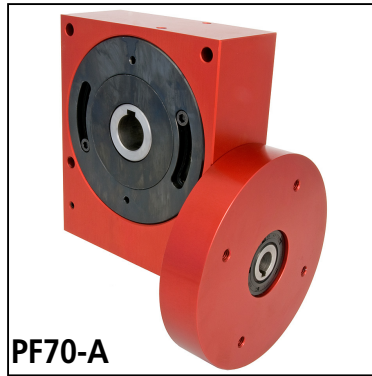

**PF70-A**

### Input Detail

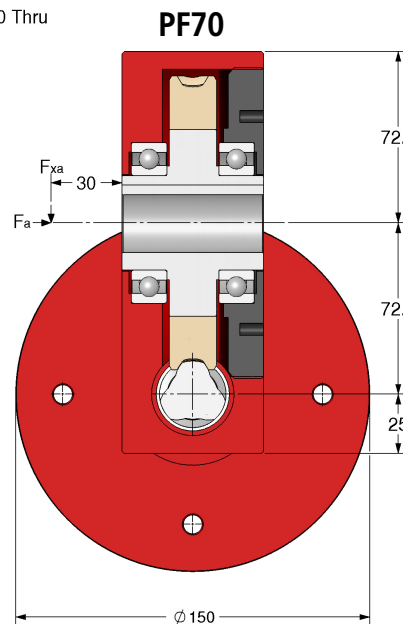
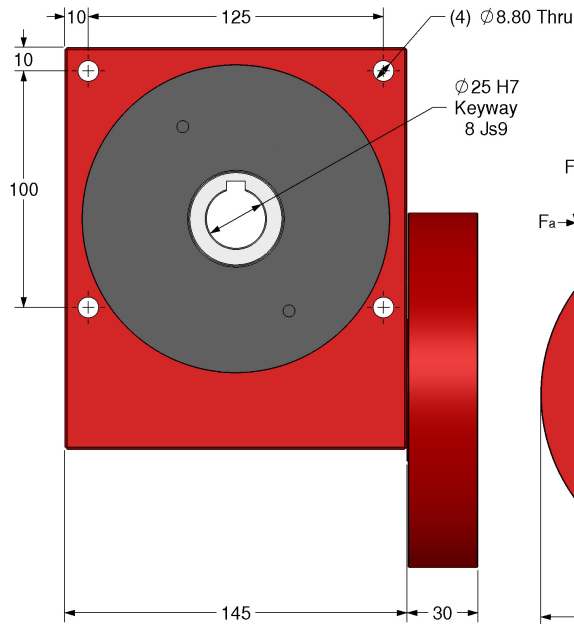
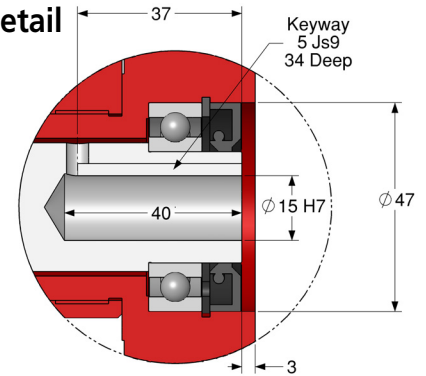

**PF70**

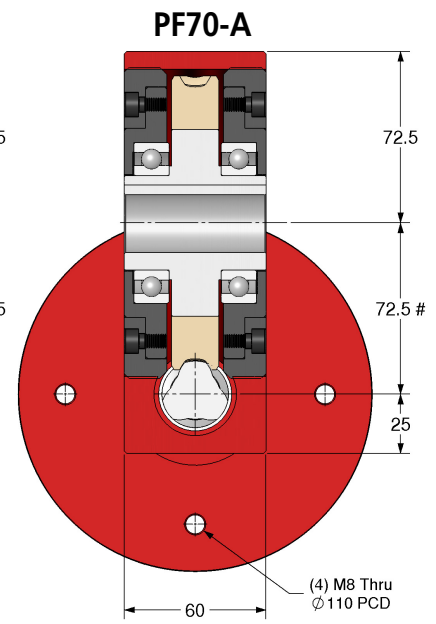

**PF70-A**

# PF70A version (low backlash) output is on eccentric so centres will vary.

**Discounts: 6+ -5% 20+ -10% 50+ -15% 100+ -20%**

Standard ≤30'	Part Number		Ratio	Efficiency at 1000 Rpm	Reflected Inertia at Input (kg.m <sup>2</sup> )	Self Locking Output	Price Each 1 - 5		
	Low Backlash ≤8'	Red. Backlash ≤4'					Standard	Low Backlash	Reduced Backlash
PF70-10	PF70-10A	PF70-10AR	10:1	90%	4.81 x 10 <sup>-5</sup>	✗	£409.03	£576.67	£692.00
PF70-12	PF70-12A	PF70-12AR	12:1	89%	4.19 x 10 <sup>-5</sup>	✗	£409.03	£576.67	£692.00
PF70-15	PF70-15A	PF70-15AR	15:1	86%	3.70 x 10 <sup>-5</sup>	✗	£409.03	£576.67	£692.00
PF70-20	PF70-20A	PF70-20AR	20:1	85%	3.28 x 10 <sup>-5</sup>	✗	£409.03	£576.67	£692.00
PF70-30	PF70-30A	PF70-30AR	30:1	78%	3.00 x 10 <sup>-5</sup>	✗	£409.03	£576.67	£692.00
PF70-60	PF70-60A	PF70-60AR	60:1	67%	2.89 x 10 <sup>-5</sup>	✓	£409.03	£576.67	£692.00
PF70-120	PF70-120A	PF70-120AR	120:1	50%	2.76 x 10 <sup>-5</sup>	✓	£409.03	£576.67	£692.00
PF70-SP	PF70-SPA	PF70-SPAR	5:1-120:1	Special Ratios: Replace SP with required ratio			£483.93	£576.67	£761.21

### Accessories

P70-X	P70-DX	Output Shafts	Single	Double
KK8-7-40		Output Key	£29.82	£36.34
			£1.15	

Weight: 7.90kg. Greased for life: Shell Gadus S5 V42P 2.5.  
F<sub>xa</sub> at 1000rpm: 80kg. F<sub>a</sub> at 1000rpm: 60kg.

Tapped holes on input flange are not relative in position to the gearbox body and will alter from box to box. However, we can machine the tapped holes after assembly so they are relative in position to the gearbox body. This will affect delivery.

### Motor Inputs also available.

Testing in your application is necessary.

You will need to assess duty cycles and confirm gearbox suitability with your own calculations.

All figures listed are to be used for guidance only.

### Output Torque Nm

Rpm Input	Reduction Ratio						
	10:1	12:1	15:1	20:1	30:1	60:1	120:1
3000	38.0	40.0	42.0	45.0	50.0	56.0	38.0
2000	47.0	49.0	53.0	55.0	61.0	69.0	46.0
1000	61.0	65.0	67.0	71.0	73.0	83.0	55.0
500	77.0	81.0	83.0	87.0	91.0	100.0	66.0
200	99.0	101.0	105.0	107.0	113.0	121.0	77.0
100	115.0	119.0	121.0	123.0	129.0	133.0	86.0
50	129.0	133.0	137.0	139.0	144.0	146.0	90.0
10	160.0	160.0	160.0	164.0	164.0	164.0	90.0

+44 (0)1246 455500  
+44 (0)1246 455522

**ondrives**

sales@ondrives.com  
www.ondrives.com

Product information updated 1st April 2011 and subject to change. Please contact Sales for the latest prices and availability.