

GEARBOXES

Precision Worm Gear Reducers

Nema 23 Flange Input 5Nm – 18Nm **5:1 - 120:1**

e-cad
Drawings
Available

PF40NM



PF40-NM



PF40-ANM

Input Detail

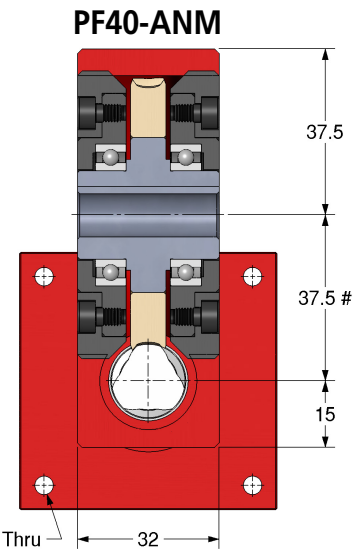
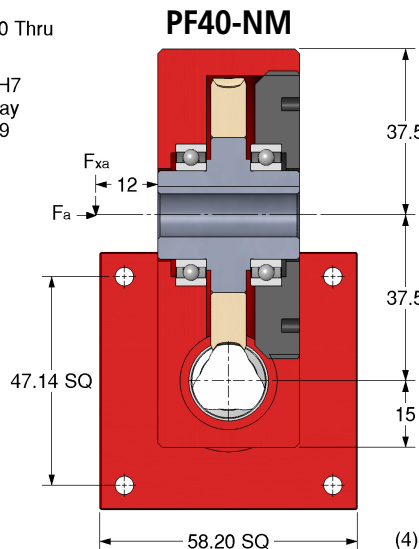
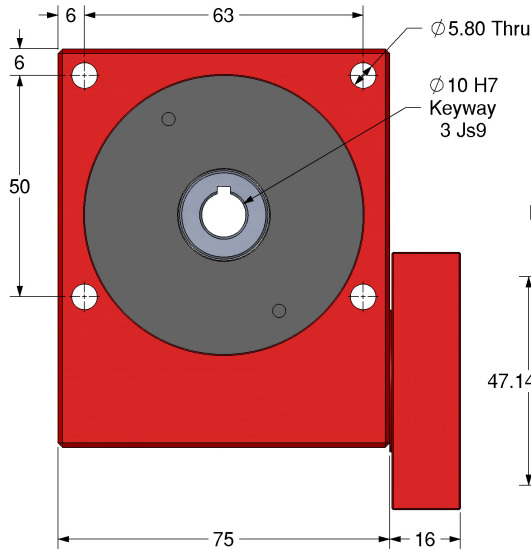
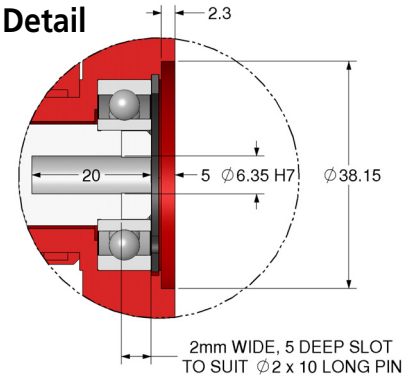

PF40ANM version (low backlash) output is on eccentric so centres will vary.

Discounts: 6+ -5% 20+ -10% 50+ -15% 100+ -20%

Part Number		Ratio	Efficiency at 1000 Rpm	Reflected Inertia at Input (kg.m ²)	Self Locking Output	Price Each 1 - 5	
Standard ≤30'	Low Backlash ≤8'					Standard	Low Backlash
PF40-10NM	PF40-10ANM	10:1	89%	3.78 x 10 ⁻⁶	✗	£233.34	£389.39
PF40-12NM	PF40-12ANM	12:1	87%	3.62 x 10 ⁻⁶	✗	£233.34	£389.39
PF40-15NM	PF40-15ANM	15:1	85%	3.49 x 10 ⁻⁶	✗	£233.34	£389.39
PF40-20NM	PF40-20ANM	20:1	83%	3.39 x 10 ⁻⁶	✗	£233.34	£389.39
PF40-30NM	PF40-30ANM	30:1	76%	3.32 x 10 ⁻⁶	✗	£233.34	£389.39
PF40-60NM	PF40-60ANM	60:1	65%	3.27 x 10 ⁻⁶	✓	£233.34	£389.39
PF40-120NM	PF40-120ANM	120:1	41%	3.26 x 10 ⁻⁶	✓	£233.34	£389.39
PF40-SPNM	PF40-SPANM	5:1-120:1	Special Ratios: Replace SP with required ratio			£309.69	£389.39
Accessories						Single	Double
P40-X	P40-DX	Output Shafts				£18.57	£23.03
KK3-20		Output Key				£0.91	

Weight: 1.15kg. Greased for life: Shell Gadus S5 V42P 2.5.
F_{xa} at 1000rpm: 30kg. F_a at 1000rpm: 20kg.

Modifications and custom designed gearboxes available. Contact Sales for details.
Testing in your application is necessary.
You will need to assess duty cycles and confirm suitability with your own calculations.
All figures listed are to be used for guidance only.

Output Torque Nm

Rpm Input	Reduction Ratio						
	10:1	12:1	15:1	20:1	30:1	60:1	120:1
3000	5.00	5.20	5.40	5.60	6.40	7.20	6.50
2000	5.50	5.80	6.20	6.60	7.30	8.00	7.20
1000	7.10	7.50	8.00	8.20	9.00	10.00	8.70
500	8.90	9.10	9.60	10.00	10.50	11.40	10.20
200	11.60	11.90	12.30	12.50	13.50	14.20	11.70
100	13.40	13.60	14.10	14.60	15.30	16.00	12.30
50	15.10	15.50	16.20	16.40	17.30	17.60	12.30
10	17.60	17.60	17.60	17.70	17.80	18.00	12.30

+44 (0)1246 455500
+44 (0)1246 455522

ondrives

sales@ondrives.com
www.ondrives.com

Product information updated 1st April 2011 and subject to change. Please contact Sales for the latest prices and availability.