

COUPLINGS

ROBA®-lastic Flexible Safety Coupling

2 to 1400Nm (Sizes 0-5)

Adjusting Nuts

The standard adjusting nut for sizes 0-5 (adjusting nut 0, figure 9), is adjusted with a face wrench (figure 13). The adjusting nut is secured using a lock washer with 4 tabs, as well as 1 hexagon screw which is screwed through the adjusting nut into the holes in the lock washer.

Maintenance – Assembly

This slip hub is easy to clean as a result of its smooth design. When the friction linings become worn, the slip hub has to be adjusted and, in the case of more extensive wear, the friction linings must be changed. Otherwise, the slip hub needs no maintenance at all. During assembly, it must be ensured that no oil or grease gets onto the friction surfaces. In addition, the drive element must have a precision ground surface and precisely parallel faces in the region of the friction surface.

Fig.9 Adjusting Nut 0
Sizes 0-5

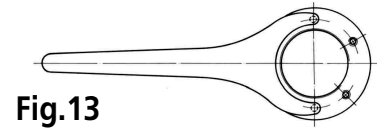

Fig.13

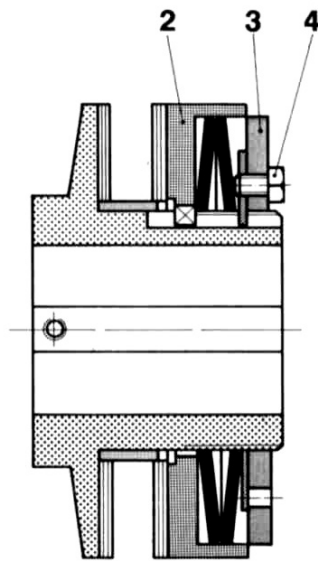
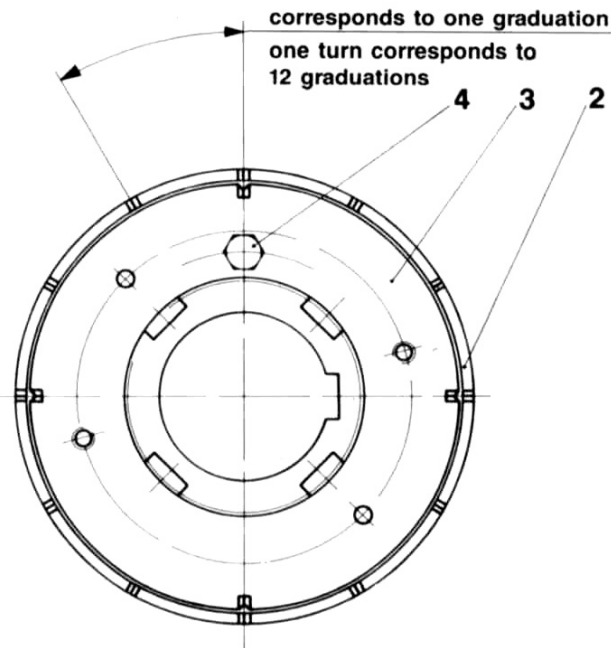

Fig.15

Adjusting the Torque

In the case of these slip hubs of sizes 1-5, the thrust washer (item 2) has twelve markings on the back (24 markings in the case of size 0) and the adjusting nut (item 3) has four markings (figure 15). The adjusting nut and lock washer are moved manually until they make contact with the cup springs; the four notches in the adjusting nut and the notches in the thrust washer must coincide when doing so. The adjusting nut is now turned by the number of graduations corresponding to the required torque. A setting chart (below) is glued on the clutch and can be used to obtain the number of graduations to be set, to suit the torque. If a torque value falls between two graduations, the lower value should be set (positive spring force tolerance). After the torque has been set, the adjusting nut must be secured by tightening the set screw (item 4).

ROBA® slip hub size 3	Turn nut to contact cup spring; then count TS 12 TS = 1 turn	Single cup spring	Torque Nm											
			50	85	109	133	155	174	192	210	233	250		
Surface ground chain sprocket for friction lining no. 1 run-in condition			Graduations			TS								
			5	8	10	12	14	16	18	20	23	26		
		Double cup spring	Torque Nm			Graduations TS								
			239	289	336	377	420	460	490	520	550			
			7	8	9	10	11	12	13	14	15			

No setting chart is attached to the slip hub with triple spring layers. The torque is set as follows – tighten the adjusting nut without using excessive force, then tighten the individual screws in the adjusting nut uniformly approx. 1/4 turn until the requisite torque is obtained. When being set for the first time, the slip hub should slip a few times at 50% of the maximum torque indicated in the catalogue in order to obtain a clean contact pattern on the friction lining. Depending on the slipping frequency, occasional adjustment is necessary as a result of lining wear. The slip hub can be supplied complete with drive element and pre-set torque for an extra charge.

T
E
C
H
N
I
C
A
L

COUPLINGS

ROBA®-lastic Flexible Safety Coupling

2 to 1400Nm (Sizes 0-5)

Single Layer Double Layer Triple Layer



Sizes 0-12
Fig. 1



Sizes 0-12
Fig. 2



Sizes 1-5
Fig. 3

Single Cup Spring Layer Double Cup Spring Layer

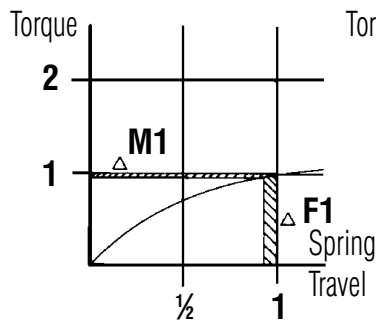

Fig. 4

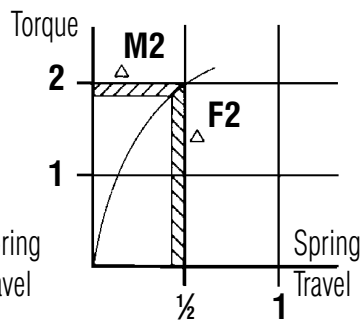

Fig. 5

Torques - Cup Spring Layers

The cup spring layers shown in figs. 1 to 3 correspond to the standard model of our slip hub. Each number of layers gives a different spring characteristic or spring force (torque). The following can be applied as a rule of thumb for using slip hubs:

Slip hub for high friction work and low torque: single-layer cup spring.

Slip hub for moderate friction work and higher torque: double-layer cup springs.

Slip hub for low friction work and very high torque: triple-layer cup springs.

The torque curve of the slip hubs, in case of friction lining wear can be seen from Figs. 4 and 5. Fig. 4 shows that the drop in torque is very low as a result of wear when using single-layer cup springs. From Fig. 5 it can be seen that the change in torque for double-layer cup springs is already greater, and that with triple-layer springs, there is the greatest drop in torque.

However, the cup springs are designed with a relatively gentle characteristic so that high wear paths are obtained without a considerable drop in torque.

For special applications, weaker cup springs are also available for the individual slip hub sizes, making it possible to go below the minimum torques.

In addition, each individual application can be satisfied with different cup spring layers (eg. combination of double and single layers).

Figs. 4 and 5 show that a torque setting in the uppermost quarter of the spring characteristic (torques) gives a particularly uniform torque, as the spring characteristic has its gentlest slope in this area.

Note: during the running in phase (bedding in of friction components) or after long periods of slippage the torque capacity may vary due to changes in the coefficient of friction and lining area.

Friction Linings

As shown in the table below, 4 different types of friction linings are available for the various applications. The torque and speed details given in the tables of dimensions apply to standard friction linings for dry running. The corresponding values for the respective application must be requested for other friction linings.

Friction Lining Number	Application
1 Supplied as Standard	Standard for dry running
2 P.O.A.	Rustproof friction lining pairing
4 P.O.A.	Bronze friction lining for oil bath
5 P.O.A.	Special low-friction material

1
A
C
I
N
H
C
E
T