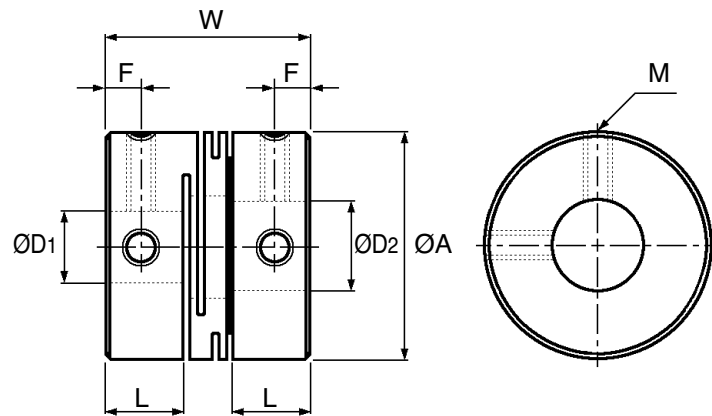

MWS

COUPLINGS

Miniature Aluminium 4 Slit Flexible Coupling

with Set Screw : 0.1 - 4Nm, 2 - 16mm Bores

**Discounts:** 6+ -10% 16+ -15% 41+ -20% 100+ -25% 200+ -30% 400+ -35%

Part Number	Standard Bores ØD1 ØD2		Max. Bore	ØA	L	W	F	M	Price Each 1 - 5
MWS-8	2	2	4	8	3.40	10	1.7	M2	£17.47
MWS-12	4	4	6	12	5.20	14	2.5	M2.5	£19.59
MWS-16	5	5	8	16	6.80	18	3.0	M3	£21.54
MWS-20	5	6	10	20	7.65	20	3.0	M3	£23.15
MWS-25	5	6	12	25	9.60	25	4.0	M4	£26.99
MWS-32	8	8	16	32	12.60	32	6.0	M4	£33.66

Part Number	Wrench Torque Nm	Rated Torque Nm	Max. Torque Nm	Max. rpm min ⁻¹	Moment of Inertia kg·m ²	Static Torsional Stiffness Nm/rad	Max Angular Offset	Max Axial End-Play mm	Mass g
MWS-8	0.3	0.1	0.2	48000	1.0x10 ⁻⁸	24	1°	± 0.1	1.0
MWS-12	0.5	0.2	0.4	32000	7.0x10 ⁻⁸	60	1°	± 0.1	3.1
MWS-16	0.7	0.3	0.6	24000	2.8x10 ⁻⁷	110	1°	± 0.2	7.4
MWS-20	0.7	0.5	1.0	19000	7.5x10 ⁻⁷	130	1°	± 0.2	12.0
MWS-25	1.7	1.0	2.0	15000	2.3x10 ⁻⁶	350	1°	± 0.2	24.0
MWS-32	1.7	2.0	4.0	12000	8.0x10 ⁻⁶	650	1°	± 0.2	50.0

The maximum torque of the miniature coupling is two-fold of the rated torque.

Select a type in which torque generated during continuous operation does not exceed the rated torque of the miniature coupling.

Material

Aluminium alloy, Anodic Oxide coated

Performance

Maximum Operating Temperature: 100°C.(approx.)

Ordering

e.g. MWS-25 - Ø8 x Ø10

Type	_____
ØD1	_____
ØD2	_____

Options

MWS coupling can be bored out.

Also available in 303 stainless steel and with clamp fixing.

Features

Light weight, short length coupling • High torsional stiffness and response • Zero backlash • Moment of low inertia • Complete absorption of angular misalignment and shaft end-play by spring action • Parallel misalignment is not absorbed • Identical clockwise and anti-clockwise rotational characteristics • Maintenance free and excellent resistance to oil and chemicals • Ideal one-piece metallic spring coupling

Other Info.

Flexible couplings transmit torque and rotational angle while absorbing misalignment. When the misalignment exceeds allowable values, vibration may result or the life of the coupling may become shortened. Make sure to adjust the alignment accordingly.

There are three types of shaft misalignment, namely in terms of parallel misalignment, angular misalignment and shaft end-play. Adjust the alignment to be below allowable values listed in the specification table of each miniature coupling. The maximum misalignment listed within this range is the allowable value only when one of the misalignments exists. In case two or more misalignments exist at the same time, the allowable values will be less than 50% of the maximum misalignment listed in the specification tables. Misalignments are sometimes caused not only by equipment assembly, but also by vibration, heat expansion, wear of bearings, etc during operation. Therefore, it is recommended to adjust the shaft misalignment to be below 1/2 of maximum values.

Important: Couplings and other rotational parts should be protected by covers for safety operation. Also, take note that operation under misalignment exceeding maximum values and excessive torque may result in shorter life of the coupling due to plastic deformation.

+44 (0)1246 455500

+44 (0)1246 455522

ondrives

sales@ondrives.com

www.ondrives.com

Product information updated 1st April 2011 and subject to change. Please contact Sales for the latest prices and availability.