

**AW**

# ANTI-VIBRATION & SPRINGS

## Anti-Vibration Washers

Round

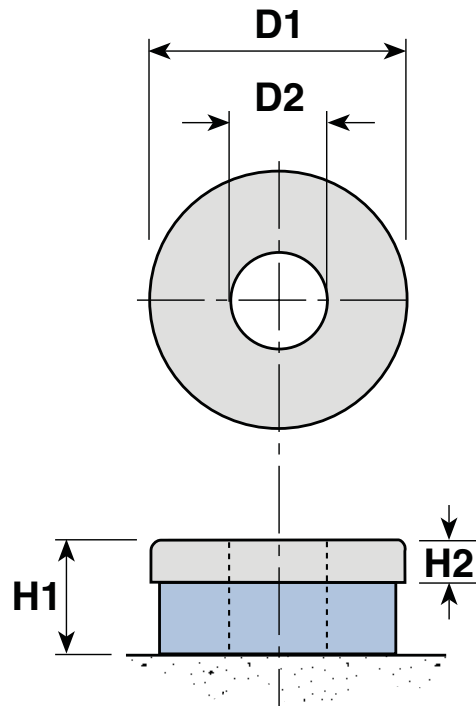

Part Number	D1	D2	H1	H2	Max. Tightening Torque T Nm	Corresponding Bolt Tension F kN	Price Each
AW-10	30	11	11	5	7	4	£P.O.A
AW-12	30	13	11	5	13	6	£P.O.A
AW-14	35	15	12	6	20	8	£P.O.A
AW-16	40	17	12	6	30	10	£P.O.A
AW-20	40	21	12	6	60	13	£P.O.A
AW-24	50	25	14	8	90	18	£P.O.A
AW-30	60	31	14	8	140	24	£P.O.A
AW-36	70	37	16	10	230	33	£P.O.A

### Material

SG 6P2 general purpose machine mounting anti-vibration material.

### Other Info.

AW anti-vibration washers reduce vibration transmitted to or from holding down bolts. The washers are placed between the hold down nut and machine base or flange.

Tightening torques 'T' relate to dry, unplated, metric coarse threads. If higher tightening torques are required, Contact sales for further details.

+44 (0)1246 455500  
+44 (0)1246 455522

**ondrives**

sales@ondrives.com  
www.ondrives.com

Product information updated 1st April 2011 and subject to change. Please contact Sales for the latest prices and availability.